

# Environmental Product Declaration

In accordance with ISO 14025 and EN 15804:2012+A2:2019 for:

**FIL35, FIL45, FIL50, FIL70 and FIL120**  
**Modular Linear Technical**  
***Luminaires***

Programme **The International EPD® System, [environdec.com](http://environdec.com)**

Programme operator **EPD International AB**

EPD registration number **S-P-05607**

Publication date **2022-03-14**

Valid until **2027-03-13**

*An EPD should provide current information and may be updated if conditions change. The stated validity is therefore subject to the continued registration and publication at [www.environdec.com](http://www.environdec.com)*



---

# Table of Content

---

<b>General information</b>	Programme information	<a href="#"><u>3</u></a>
	Company information	<a href="#"><u>4</u></a>
	Product information	<a href="#"><u>6</u></a>
<b>LCA information</b>	A1-A3 Product stage	<a href="#"><u>19</u></a>
	A4-A5 Installation stage	<a href="#"><u>20</u></a>
	B1-B7 Use stage	<a href="#"><u>21</u></a>
	C1-C4 End of life stage	<a href="#"><u>21</u></a>
	D Reuse, recovery and recycling stage	<a href="#"><u>22</u></a>
<b>Additional information</b>		<a href="#"><u>24</u></a>
<b>Content information</b>		<a href="#"><u>25</u></a>
<b>Environmental information</b>		<a href="#"><u>26</u></a>
<b>Information related to Sector EPD</b>		<a href="#"><u>33</u></a>
<b>References</b>		<a href="#"><u>33</u></a>

# General information

## Programme information

---

**Programme** The International EPD® System

---

**Direction** EPD International AB  
Box 210 60  
SE-100 31 Stockholm  
Sweden

---

**Website** [www.environdec.com](http://www.environdec.com)

---

**E-mail** [info@environdec.com](mailto:info@environdec.com)

---

CEN standard EN 15804 serves as the Core Product Category Rules (PCR).

---

**Product category rules (PCR):** PCR 2019:14 Construction Products (EN 15804: A2), version 1.11.

---

**PCR review was conducted by:**

El Comité Técnico del Sistema Internacional EPD®.

**President:**

Claudia A. Peña. Contact via [info@environdec.com](mailto:info@environdec.com)

---

Independent third-party verification of the declaration and data, according to ISO 14025:2006:

EPD process certification       EPD verification

---

**Third party verifier:**

Marcel Gómez Consultoria Ambiental. Verifier: Marcel Gómez Ferrer  
Phone: +34 630 64 35 93  
Email: [info@marcelgomez.com](mailto:info@marcelgomez.com)  
Website: [www.marcelgomez.com](http://www.marcelgomez.com)

---

Procedure for follow-up of data during EPD validity involves third party verifier:

Yes     No

---

The EPD owner has the sole ownership, liability, and responsibility for the EPD.

EPDs within the same product category but from different programmes may not be comparable. EPDs of construction products may not be comparable if they do not comply with EN 15804. For further information about comparability, see EN 15804 and ISO 14025.

## Company information

---

**Owner of the EPD** LAMP S.A.U.

---

**Contact** Xavi Marba — Quality Manager  
+34 937 366 800  
xavi\_marba@lamp.es  
<https://www.lamp.es/>

---

**Description of the organization** **LAMP** designs, develops and produces interior and exterior lightings of power supply voltages not exceeding 1000V with commitment to quality and respect for the environment as strategic factors to our products and services. The company was born in Terrassa (Spain) in 1972 as a fluorescent store and there are currently more than 600,000 Lamp's lighting products in 70 countries around the world.

Consulting, designing, producing, marketing and launching technical lighting projects. Lamp's seal, a commitment that has been maintained for more than 45 years is to turn any lighting challenges into reality with a solvent and made-to-measure response in any architectural project in the world. **Lamp is work and attitude, it is Worktitude for Light.**



**Worktitude for Wellbeing:** We conceive lighting as a key element for improving the well-being of people, analysing the visual and non-visual effects of light. We believe that light is born in every luminaire, but lives in the space it illuminates and in the person who works or lives there. Whether it is a product or a project, we build on and for users, taking into account the physical characteristics of the space and the kind of tasks that will be carried out there. We are committed to honesty, durability, responsibility, and suitability.



**Worktitude for Life:** We foster the development of projects that have a positive impact on the environment and promote a more sustainable lighting industry. We believe that bringing a space to life requires the shared effort of many businesses and professionals working responsibly with the purpose of reducing the environmental impact along the entire value chain. We do our bit by providing realistic, efficient, and sustainable solutions aligned with the current climate situation.



**Worktitude for Innovation:** We promote and develop innovative projects oriented towards cross-sectional and constant improvement, understanding that innovation is a systemic and systematic process. The combination of design and engineering creates a useful product and provides meaning as well as comfort to indoor and outdoor architectural projects that require demanding features. We anticipate the needs of architects, lighting designers, engineers, and interior designers to make their projects come true and provide the future with light, creating lighting solutions that respond to new lifestyles.

---

**Certifications related to the product or the management system**

Lamp 's fundamental purpose is to achieve full customer satisfaction by meeting and exceeding their expectations, while generating the least possible environmental impacts. This philosophy basically responds to the application and implementation of the following points:

— Lamp's products must comply with all legal regulations required in the Spanish and European Regulations (EC), e.g. EN 62471 Photobiological safety.

— Compliance with applicable environmental legislation and regulations, as well as endorsed voluntary requirements.

— A quality and environmental management system based on the UNE-EN ISO 9001:2015 and UNE-EN ISO 14001:2015 standards, which facilitates labor and improves continuously the offered products and services in an environmentally respectful manner.

---

**Name and location of production site**

C/ Córdoba 16, 08226 Terrassa (Barcelona), Spain.

## Product information

---

### Product name

This EPD® represents the FIL family of Lamp, including the following models:

**Fil 35** of **surface, recessed and trimless** installation, in **six lengths, two types of switches** and **three finishing colors**, covering the following 3 typologies:

- Fil 35 Direct
- Fil 35 Direct / Indirect
- Fil 35 Corner

**Fil 45** of **surface and recessed** installation, in **six lengths, two types of switches** and **three finishing colors**, covering the following 8 named typologies:

- Fil 45 Direct Opal
- Fil 45 Direct Opal Comfort
- Fil 45 Direct Tech
- Fil 45 Direct Tunable White
- Fil 45 Direct Wellbeing
- Fil 45 Direct Tunable White WB
- Fil 45 Direct Indirect
- Fil 45 Corner

**Fil 50** of **surface and recessed** installation, in **two lengths, two types of switches** and **two finishing colors**.

**Fil 70** of **surface and recessed** installation, in **four lengths, two types of switches** and **two finishing colors**, covering the following 3 typologies:

- Fil 70 Direct
- Fil 70 Direct Tech
- Fil 70 Direct / Indirect
- Fil 70 Corner

**Fil 120** of **surface and recessed** installation, in **two lengths, two types of switches** and **two finishing colors**.

**Product identification:** Modular linear technical luminaire.

The references available on the market are differentiated by a combination of codes. These codes indicate a series of characteristics such as type of installation, dimensions, light unit, color rendering index, type of color in Kelvin degree, type of switch and finishing color. The references studied in this EPD (divided by diffuser model) are:

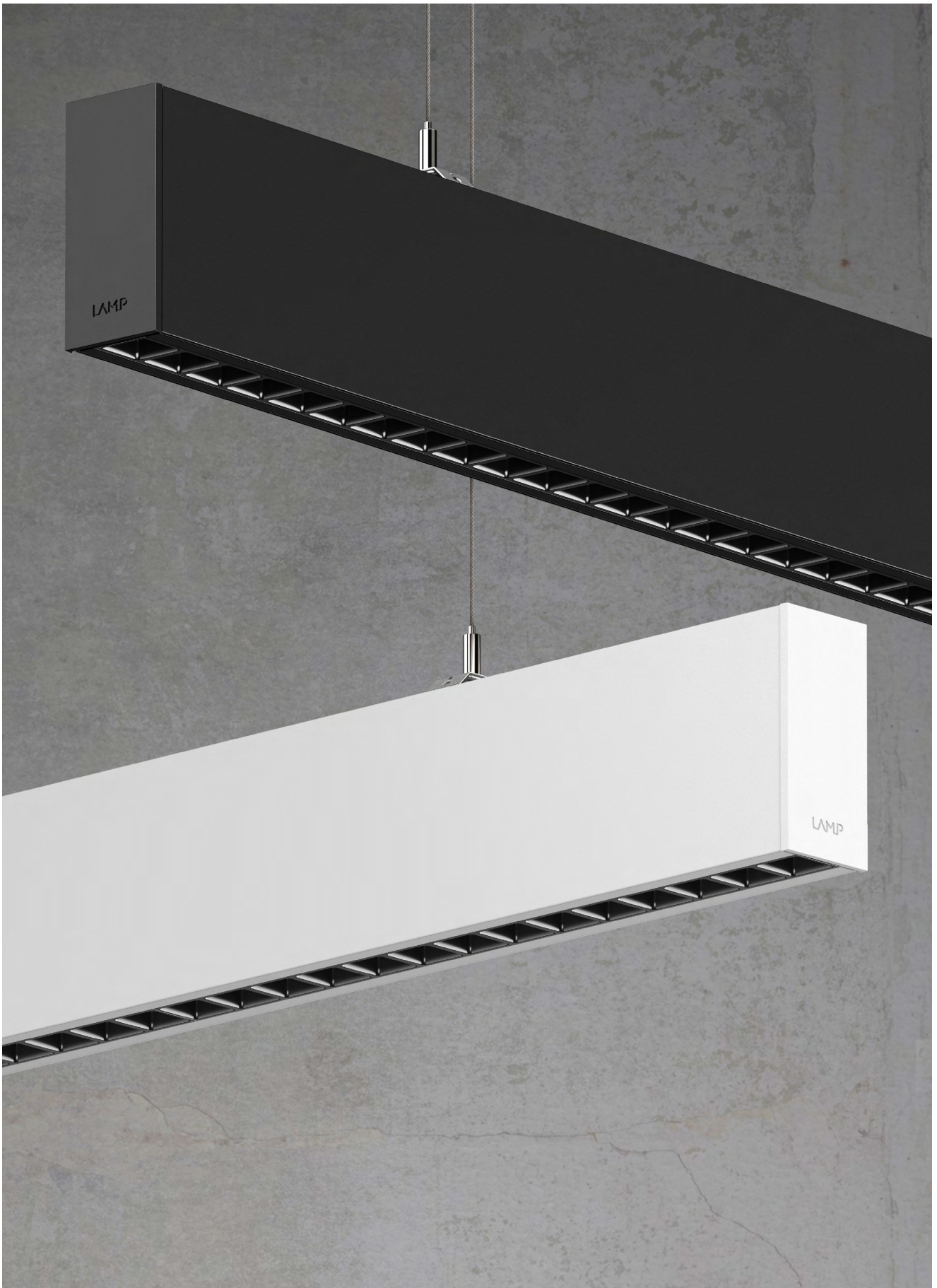

# Fil 35

## F31 SF 084 LO OP 8 30 N B

\*Including all FIL 45 family references

Models	OPAL		OPAL COMFORT		TECH		DIRECT/INDIRECT		
									
Installation	SURFACE		RECESSED		TRIMLESS		DIRECT/INDIRECT		
									
Lm LED	1200 lm	1470 lm	1600 lm	2000 lm	2400 lm	2650 lm	2800 lm	3200 lm	
Lengths	840 mm	1120 mm	1400 mm	1680 mm	1960 mm	2240 mm			
IRC	80 / 90								
Opening angles	Opal 		Opal Comfort 		Tech 		Direct/Indirect 		
Temp. Color	3000 / 4000 K								
Equipment	ON / OFF - DALI								
Power	8 W	11 W	12 W	14 W	16 W	18 W	19 W	22 W	32 W
Finishing	● Black		○ White 02		● Grey 01				



# Fil 45

## F41 SF 084 MO OP 8 30 N B





\*Including all FIL 45 family references

<b>Models</b>	OPAL	OPAL COMFORT		TECH	DIRECT/INDIRECT	
						
<b>Installation</b>	SURFACE	RECESSED		DIRECT/INDIRECT		
						
<b>Lm LED</b>	1450 lm 4650 lm	2600 lm 6200 lm	3250 lm 7750 lm	3900 lm 9300 lm	4550 lm 10850 lm	3200 lm 12400 lm
<b>Lengths</b>	840 mm	1120 mm	1400 mm	1680 mm	1960 mm	2240 mm
<b>IRC</b>	80 / 90					
<b>Opening angles</b>	Opal 	Opal Comfort 		Tech 	Direct/Indirect 	
<b>Temp. Color</b>	3000 / 4000 K / TW / WB					
<b>Equipment</b>	ON / OFF - DALI					
<b>Power</b>	12 W 27 W	161 W 36 W	19 W 45 W	23 W 54 W	27 W 63 W	31 W 72 W
<b>Finishing</b>	● Black		○ White 02	● Grey 01		

# Fil 50

## F51 SF 120 MO OP 8 30 N W

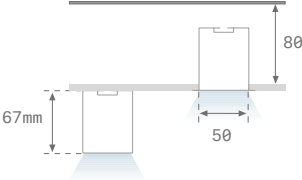
\*Including all FIL 45 family references

Models	OPAL	PRISMATIC
		
<b>Installation</b>		
<b>Lengths</b>	1137 mm	1700 mm
<b>Lm LED</b>	3000 lm 6000 lm	4600 lm 9200 lm
<b>IRC</b>	80	
<b>Opening angles</b>	Opal 	Prismatic 
<b>Temp. Color</b>	3000 / 4000 K	
<b>Equipment</b>	ON / OFF - DALI	
<b>Power</b>	19 W 37 W	28 W 55 W
<b>Finishing</b>	○ White 02	● Grey 01

# Fil 70

## F71 SF 120 LO OP 8 30 N W

\*Including all FIL 45 family references

<b>Models</b>	OPAL	PRISMATIC	DIRECT/INDIRECT	TECH/TECH ASYMMETRIC	
					
<b>Installation</b>	SURFACE	RECESSED	SURFACE	SURFACE	RECESSED
					
<b>Lengths</b>	1162 mm	1743 mm		1000 mm	2000 mm
<b>Lm LED</b>	2600 lm 4400 lm	3900 lm 6600 lm		1600 lm 3200 lm	3200 lm 6400 lm
<b>IRC</b>	80				
<b>Opening angles</b>	Opal 	Prismatic 	Opal 	Tech 	Tech Asym. 
<b>Temp. Color</b>	3000 / 4000 K				
<b>Equipment</b>	ON / OFF - DALI				
<b>Power</b>	17 W 28 W	25 W 41 W		12 W 21 W	25 W 42 W
<b>Finishing</b>	○ White 02		● Grey 01		

# Fil 120

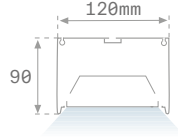

Family	Installation	Formats	Lm LED	Optic	IRC	K	Equipment	Finishing
<b>F121</b>	<b>SF</b> Surface	<b>12</b> 1162mm	<b>HO</b> 6500lm	<b>OP</b> Opal	<b>8</b> 80	<b>30</b> 3000K	<b>N</b> ON/OFF	<b>W</b> White 02
	<b>RE</b> Recessed	<b>17</b> 1743mm					<b>D</b> DALI	<b>G</b> Grey 01
<b>F121</b>	<b>SF</b>	<b>12</b>	<b>HO</b>	<b>OP</b>	<b>8</b>	<b>30</b>	<b>N</b>	<b>W</b>

Opticians

## OP

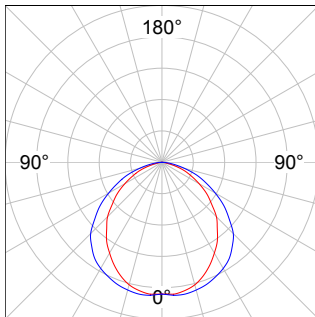

7642003  
 $\eta = 56\%$   
 $I_{max} = 213 \text{ cd/klm}$   
 UTE: 0,56D  
 CIE: 51 83 98 100 56

Output flow and power

## FIL 120

	K	CRI	1162mm		1742mm	
			W	lm Output	W	lm Output
OP	3000	80	49	5090	71,7	7735
	4000	80	49	5290	71,7	7735

# Product description

Firstly, the general description of the studied models is presented:

## 1. FIL 35

Fil 35 is a linear luminaire family with a wide range of lengths with dimensions miniaturization that allows a high integration of the product in space.

Available for surface, recessed and recessed trimless installations, with six standardized lengths and black, white or grey matt finishing. Integrates MID-POWER LED technology with warm white and neutral white colour temperature. Models with DALI regulation drivers are available.

## 2. FIL 45

Fil 45 is a linear luminaire family with a wide range of optical solutions with dimensions optimization and wide range of lighting distributions which allow high versatility to adapt to technical requirements in space.

Available in direct and indirect distributions with opal, opal comfort or tech diffuser solutions for better glare control. Also available for surface-mounted and recessed installation, with six standardised lengths and the option of a horizontal corner format.

Available in black, white and matt grey finishes. Integrates medium-power LED technology with warm white or neutral white colour temperature, also with a version in dynamic white. Incorporates wellbeing technology to optimise the circadian cycle.

## 3. FIL 50

Fil 50 is a comprehensive family of modular structures that its diffusers, reflectors, accessories and different dimensions grand great versatility, making it an ideal option for general lighting in offices, hotels, restaurants, schools, etc. Available for surface-mounted and recessed installation.

Fil 50 is a profile made of satin grey or matt white lacquered extruded aluminium. Models for MID-POWER LED. With opal and prismatic polycarbonate diffuser. With an IP20 or IP42 protection rating. Insulation class I.

Controllable under the Casambi protocol.

## 4. FIL 70

Fil is a comprehensive family of modular structures that its diffusers, reflectors, accessories and different dimensions grand great versatility, making it an ideal option for general lighting in offices, hotels, restaurants, schools, etc. Available for surface-mounted and recessed installation, in satin grey as well as white matt finishing.

Fil 70 recessed is also available with no frame, Fil 70 Trimless, providing continuous lighting without dark areas with opal and prismatic polycarbonate diffuser. In the technical models, Fil 70 Tech, the double parabola optics ensures a UGR<19.

Fil 70 Tech Asym with asymmetric distribution allows perimeter lighting or wall washer applications. Fil 70 Corner is designed to illuminate corners.

There are models available with DALI adjustable equipment.

## 5. FIL 120

Fil is a comprehensive family of modular structures that its diffusers, reflectors, accessories and different dimensions grant great versatility, making it an ideal option for general lighting in offices, hotels, restaurants, schools, etc. Available for surface-mounted and recessed installation, in satin grey as well as white matt finishing.

Fil 120 is the specialized model to illuminate spaces with great height.

All five models under study are fabricated by extruding recycled aluminium (recycled composition between 80-85%), in such way reducing carbon footprint and environmental impact. Luminaire classified as "Free of photobiological risk" in accordance with the EN 62471 normative.

The three available finishing colors black, grey and white are shown in the images below:

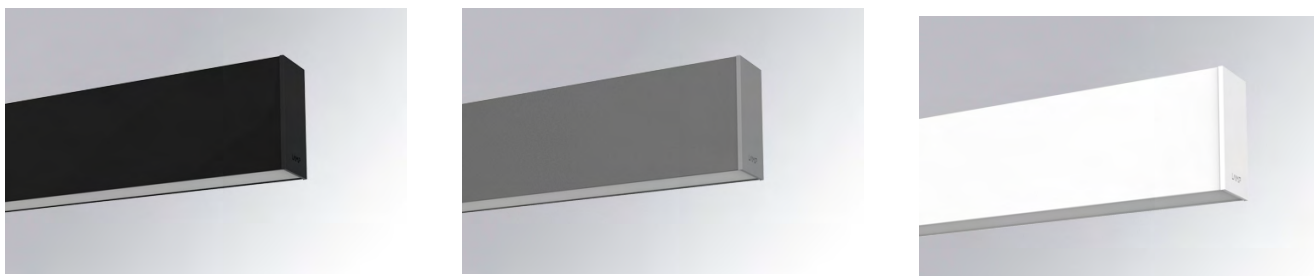

At the composition level, all the luminaires of the FIL family are mainly composed of an aluminum body (profile) that contains a polycarbonate diffuser, a LED module, a LED Driver (switch), electrical cables and fixation elements, such as steel screws, cable ducts and LED fixing pieces. According to the tables in the [Product Identification](#) section, among Fil30, Fil45, Fil50, Fil70 and Fil120 **models**, the difference is the **width of the aluminum profile**, where the numerical code indicates the width of the product in mm. The **typologies** available for each model are differentiated by **(1) types of installation, (2) types of diffusers and (3) type of switch**. In terms of potential environmental impact, among these, the following characteristics are considered:

**1. Types of installation:** The aluminum body (profile) of surface installation is slightly higher than that of the recessed installation (80 mm and 76 mm, respectively, see figures 1 and 2), with a difference in mass of 4%

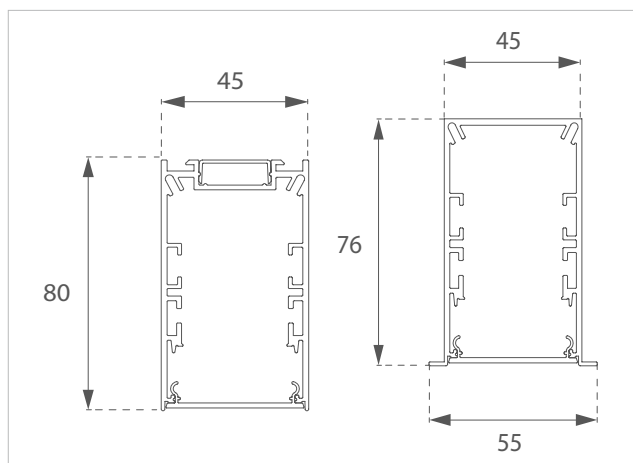

Figure 1. Example of the cross section of the aluminum profile for surface (left) and recessed (right) installation in Model Fil45

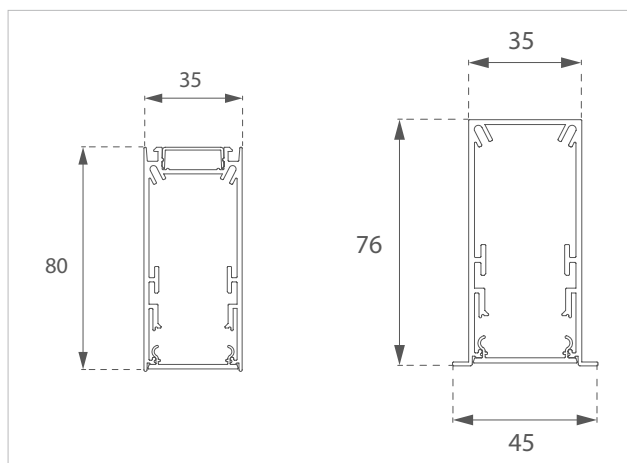

Figure 2. Example of the cross section of the aluminum profile for surface (left) and recessed (right) installation in Model Fil35

**2. Types of diffusors:** Opal, Opal Comfort, Tech and Prismatic. These pieces are made of polycarbonates in different shapes and finishes:

	Opal	Opal Comfort	Tech
<b>Material</b>	Polycarbonate		
<b>Color</b>	Opal	White on the sides, clear in the middle.	Transparent inside and white outside.
<b>Kg/m</b>	0,014	0,014	0,022

**3. Type of switch:** On/Off and Dali (Adjustable). While these two have a similar casing, the Dali unit has a more complicated PCB, allowing regulation between 1% and 100%, which will consume less energy than the On/Off unit.

	On / Off	Dali
<b>Nature</b>	LED Driver	
<b>Unit weight (kg)</b>	0,163	0,207

Sensitivity analysis performed on the differential components of each reference has shown that the difference in potential environmental impact of the different types of installation, color of diffuser and type of switch (Driver) does not affect more than 10% of the total potential impact of a luminaire unit, therefore the grouping of the results according to UNE-EN 15804:2012+A2:2019 is complied.

Finally, the technical characteristics of the luminaires are presented with one representative for surface installation and another for recessed installation:

#### 1. Surface installation: Reference **F41SF112MOPR830NG**

Lamp's surface structure for suspension or attachment. Made of matt grey painted extruded aluminium with comfort opal diffuser made of translucent polycarbonate and optic sheet for a light distribution and glare control below UGR19. Model for MID-POWER LED, with warm white color temperature and included control gear. Protection degree IP20, IK07. Insulation class I. Photobiological safety group 0.

The technical characteristics of this model are indicated in the following table:

<b>Output flow</b>	<b>1,671 lm</b>	<b>Pled</b>	<b>16 W</b>
<b>Plum</b>	17,5 W	<b>K</b>	3000
<b>Effectiveness</b>	95,4 lm/w	<b>IRC</b>	80
<b>UGR</b>	18	<b>MacAdam</b>	3
<b>Light source</b>	MID POWER TRIDONIC	<b>Supply</b>	220-240V 50/60Hz
<b>LED life in hours</b>	70 000 L80 B10	<b>Switch</b>	Electronic



Lastly, the photometric data is:

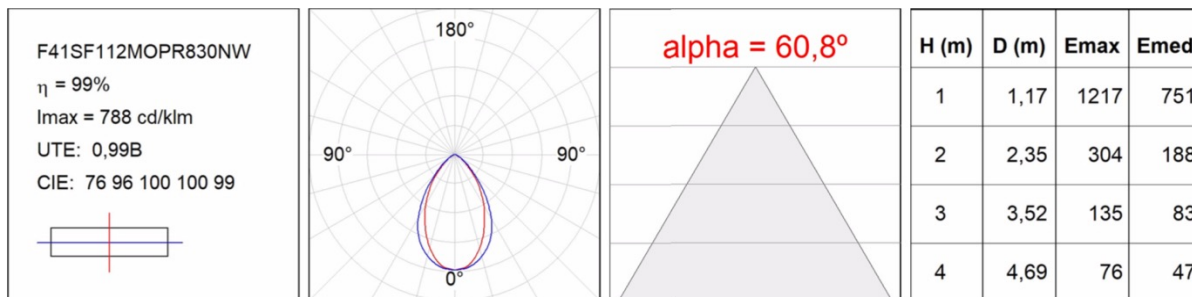

**2. Resessed installation: Reference F41RE112MOPR830NG**

Lamp’s recessed structure. Made of matt grey painted extruded aluminium with comfort opal diffuser made of translucent polycarbonate and optic sheet for a light distribution and glare control below UGR19. Model for MID-POWER LED, with warm white color temperature and included control gear. Protection degree IP20, IK07. Insulation class I. Photobiological safety group 0.

The technical characteristics of this model are indicated in the following table:

<b>Output flow</b>	<b>1,671 lm</b>	<b>Pled</b>	<b>16 W</b>
<b>Plum</b>	17,5 W	<b>K</b>	3000
<b>Effectiveness</b>	95,4 lm/w	<b>IRC</b>	80
<b>UGR</b>	18	<b>MacAdam</b>	3
<b>Light source</b>	MID POWER TRIDONIC	<b>Supply</b>	220-240V 50/60Hz
<b>LED life in hours</b>	70 000 L80 B10	<b>Switch</b>	Electronic

Lastly, the photometric data is:

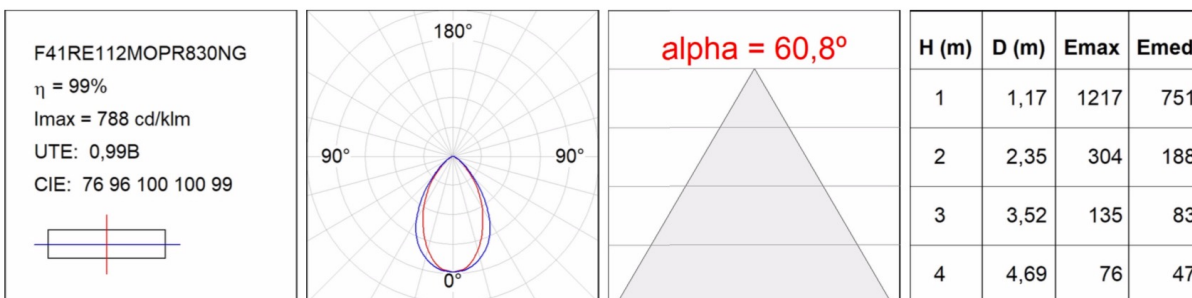



---

Aluminium R Profile



---

End Cap

---

LED Module

---

Light recovery

---

Opal Diffuser

---

TECH Reflector

---

Opal Comfort Diffuser



## LCA information

<b>Declared unit</b>	<p>The declared unit is that quantification of a function offered by the object of study according to which all the inputs (resources and necessary energy) and outputs (emissions and waste) of the studied system will be referred.</p> <p>In this case, the manufacture, distribution, installation, use and end of life of <b>one lineal meter of (1 m) Modular linear technical luminaire FIL</b> has been selected as the Declared Unit, including the fixation components.</p>
<b>Reference service life</b>	<p>is considered to be 5 years, based on the quality guarantee offered to clients.</p> <p>It should be noted that the useful life of LED can be up to 70,000 hours. In normal operational regime of 8 hours per day for 250 working days per year, the product lasts up to 35 years.</p>
<b>Temporal and geographical representativeness</b>	<p>The primary data used has been obtained from the production center of FIL product for the year 2020, being representative of the products and the production process.</p> <p>This document will be used for B2B communication, with a global scope.</p>
<b>Data quality</b>	<p>Primary data has been used regarding quantities of material (both electronic components on the market and custom profile elements and others produced internally) and energy consumed during the product's life cycle. These data have been supplied by LAMP, referring to the year 2020, and come from direct factory data.</p> <p>Secondary data was obtained from the Ecoinvent 3.6 database of recognized international prestige.</p> <p>The treatment and processing of the data has been carried out according to the international standards ISO 14025, ISOs 14040 and 14044 for the preparation of life cycle analysis and inventories, selecting the characterization factors established in the UNE 15804: 2012+ A2: 2019.</p> <p>The geographic scope of the EPD is global.</p>
<b>Database(s) and LCA software used</b>	<p>The Simapro 9.2 calculation software and the Ecoinvent 3.6 database were used for the development of this study.</p>
<b>Description of system boundaries</b>	<p>The presented EPD® is structured by the life cycle stages established according to the PCR 2019: 14 reference standards for construction products, basing on UNE 15804 standard. This EPD® is from cradle to grave with module D (A + B + C) + D.</p>

The life cycle stages analyzed are described below:

**A1 - A3 Product stage**

The product stage is made up of the stages of supply of materials (A1), transport of materials (A2) and manufacturing (A3). As permitted by the UNE-EN 15804:2012+A2:2019 regulation, the results of stages A1-A3 have been grouped into a single product stage (A1-A3).

**A1 - Material supply**

This module takes into account the acquisition and processing of both basic materials and the prefabricated components that make up the product. The generation of energy consumed in module A3 during the manufacture of the product is also assigned to this module.

**A2 - Material transport**

This module includes the transport of different materials and components from the manufacturer to the factory where the final product is made (Barcelona). The distance and type of truck and specific ship for each raw material have been introduced.

**A3 - Manufactura**

En este módulo se incluye el consumo de energía y materiales de packaging utilizados durante el proceso de manuThis module includes the consumption of energy and packaging materials used during the manufacturing process of Fil product. At the same time, factory emissions not originating from fossil fuels combustion of are analyzed, as well as the transport and management of waste originated from the plant (as well as production losses, managed externally to the production center).

It has been considered that the electrical energy consumed in the production plant is of certified 100% renewable origin.

The primary data used has been obtained from the production plant itself and is representative of the production of the Fil product for the year 2020.

The production process is described below in the following figure:

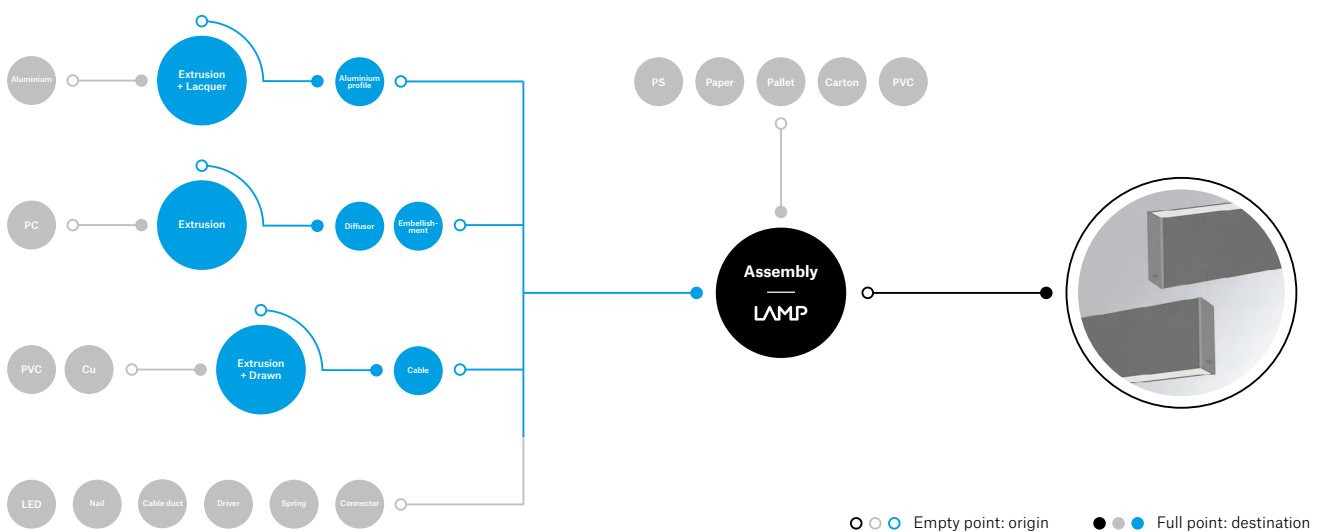

#### A4 - A5 Installation stage

The Construction Stage is made up of modules A4 Transportation and A5 Construction – Installation Process.

The **A4 Transport** module includes the transportation of finished and packaged products from the factory gate to the construction site for their subsequent installation. In the national distribution, transport by van has been considered. In global distribution, there are two means of transport: truck and plane.

A weighted average of the mileage associated with Fil products has been considered based on its sales during the year 2020. For transport by plane, the distance by truck from the production center to the departure airport, the transport by plane itself, and a truck transport from the arrival airport to a final distribution point have been taken into account.

Parameter	Description
<b>Type and fuel consumption of the vehicle, type of vehicles used for the transport; for example, trucks for long distance, boat, etc.</b>	<ul style="list-style-type: none"> <li>· Domestic: "Transport truck 3,5 - 7 t EURO6"</li> <li>· Europa: "Transport lorry 16-32 t EURO6".</li> <li>Diesel consumption: 0,0165 kg/tkm</li> <li>· "Cargo plane, no specifications". Heavy fuel oil consumption: 0.00102 kg/ tkm</li> </ul>
<b>Distance</b>	<ul style="list-style-type: none"> <li>· Km by truck: 600 km</li> <li>· Km by lorry: 1500 km</li> <li>· Km by plane: 4000 km</li> </ul>
<b>Capacity utilization (including empty return trip)</b>	% assumed by Ecoinvent
<b>Apparent density</b>	0,521 kg/m <sup>3</sup>
<b>Useful capacity factor</b>	1

Module A5 Installation Process includes all materials and energy used to prepare the product for use. At the same time, the transport and management of packaging waste and its transport to a local waste manager is taken into account.

At this stage, 0% losses are considered. Packaging waste is only considered in two treatment scenarios: recycling, with the most up-to-date packaging waste recycling rate from Eurostats (2019), and the rest is sent to a controlled landfill within a radius of 50 km.

Parameter	Description	Value per declared unit
<b>Auxiliary materials</b>	kg	0
<b>Water use</b>	M3	0
<b>Use of other resources</b>	Not applicable	0
<b>Quantitative description of the type and consumption of energy during the preparation and installation process</b>	Electricity – Drilling	330 Wh in 16 minuts
<b>Direct emissions to soil, water or air</b>	kg	0
<b>Waste materials on site, before waste processing, generated by the installation of the product; specified by type</b>	<ul style="list-style-type: none"> <li>· Installation losses</li> <li>· Packaging</li> </ul>	<ul style="list-style-type: none"> <li>· 0%</li> <li>· 0,221 kg</li> </ul>

**Output materials (specified by type) as a result of waste processing on site, eg. Eg collection for recycling, energy recovery, disposal; specified by path**

- Recycling <sup>1</sup>
- Landfill

- Paper and cardboard: 82,3%
- Mixed packaging plastics: 41%
- Wooden pallet: 31,1%
- Paper and cardboard: 17,7%
- Mixed packaging plastics: 59%
- Wooden pallet: 68,9%

## B1-B7 Use stage

This stage is comprised of:

### B1 - Use

It includes the environmental aspects and impacts in the normal use of the product, not including the consumption of water and energy. The impact of the product at this stage is null.

### B2 - Maintenance

No maintenance of any kind is required during the product's 5-year useful life.

### B3 - Repairation

No repairation is considered.

### B4 - Substitution

No substitution is considered.

### B5 - Rehabilitation

No rehabilitaion is considered.

### B6 - Operational energy use

In the guaranteed useful life of 5 years, the total electricity consumption has been estimated for a power of 17,5 W, 8 hours a day and 250 days a year. Stage B6 Operational energy use therefore has a value of 175 kWh.

### B7 - Operational water use

No water consumption is required during the product's 5-year useful life.

## C1 - C4 End of life stage

The product is required to be professionally collected and recycled in accordance with the EU Directive 2012/19/EU on Waste from Electrical and Electronic Equipment (WEEE). The company fulfills its responsibility within the EU through participation in national WEEE schemes.

### C1 - Dismantling

In this stage, the common scenario of manual dismantling for 100% of the product is considered, in which it is necessary to unscrew with electricity from the national electrical mix.

The use of auxiliary materials is not necessary.

### C2 - Transport to waste manager

In this stage, a transport to the local manager within a radius of 100 km has been considered.

### C3 - Waste treatment

At this stage, the most up-to-date Eurostats recycling and reuse rate (89,2% in 2017) from lighting equipment waste category is used <sup>2</sup>.

<sup>1</sup> Packaging recycling rate referring to 2019. Source: Eurostats.

<sup>2</sup> The indicator is calculated by multiplying the "collection rate" by the "reuse and recycling rate" established in the WEEE Directive; where:

- The 'collection rate' is equal to the collected volumes of WEEE in the reference year divided by the average quantity of electrical and electronic equipment (EEE) placed on the market in the previous three years (both expressed in units of mass).

- The 'reuse and recycling rate' is calculated by dividing the weight of WEEE entering the recycling/preparation for reuse facility by the weight of all WEEE collected separately (both in units of mass) in accordance with Article 11 (2) of the WEEE Directive 2012/19/EU, considering that the total amount of WEEE collected is sent to treatment / recycling facilities.

The indicator is expressed as a percentage (%) since both terms are measured in the same unit.

#### C4 - Final disposal

The rest of the product that has not entered the treatment system is sent to the landfill.

The following table summarizes the information necessary for the end-of-life stage:

Module	Parameter	Unit (per declared unit)	Value
<b>C1 Dismantling</b>	Collection process specified by type	· Kg collected manually and separately	· 2,176 kg
		· Kg collected mixed with construction waste	· 0
<b>C2 Transport</b>	· Vehicle type and fuel consumption, type of vehicles used for transportation · Distance · Capacity utilization (including empty return) · Useful capacity factor	· Transport truck 16t EURO6	· Diesel consumption: 0,0165 kg/tkm
		· km	· 100
		· %	· 100% volumn (round trip)
			· 1
<b>C3 Treatment of waste</b>	· System recovery specified by type	· Kg for reuse	· 0
		· Kg for recycling	· Total 1,941 kg, comprises of: Aluminium: 1,533 kg Steel: 0,023 kg Plastic components: 0,198 kg Electronic components, including cables: 0,187 kg
		· Kg for energy recovery	· 0
<b>C4 Disposal</b>	· Disposal specified by type	· Kg of product for final disposal	· Total 0,245 kg, comprises of: Aluminium: 0,186 kg Steel: 0,003 kg Plastic components: 0,024 kg Electronic components, including cables: 0,023 kg

#### D - Reuse, recovery and recycling potential stage

This product claims the environmental benefits due to recycling and reuse according to Directive 2012/19/ EU of WEEE.



## Additional information

- Technical support for the implementation of the EPD: OIKO.
- Allocation processes: Wherever possible, allocation has been avoided, but for energy consumption, waste production and distribution an allocation had to be made based on physical mass considerations.
- Cut-off rules and considerations:
  - The principle of modularity has been followed, as well as the polluter-payer principle.
  - The following processes have been excluded:
    - Manufacture of equipment used in production, in buildings or any other capital good
    - Transportation of personnel to the plant
    - Transportation of personnel within the plant
    - Research and development activities
    - Long-term emissions
- Calculation methodologies: to obtain the results in accordance with the provisions of UNE 15804 + A2, the “EF method”, “EDIP” and “CED” methodologies have been used for environmental impacts, waste generation and energy consumption, respectively.
- The scenarios included are currently in use and are representative of one of the most likely alternatives for the product under review.



## Content information

The composition range of the Fil 45 product is shown below:

Product components	Percentage, %	Post-consumer material, weight - %	Renewable material, weight - %
Aluminium	79,82 %	—	—
PC	6,23 %	—	—
Driver	4,82 %	—	—
LED module	3,33 %	—	—
PVC	2,16 %	—	—
Steel	1,18 %	—	—
PE	1,09 %	—	—
Nylon 6-6	0,77 %	—	—
Cooper	0,61 %	—	—
TOTAL	100 %	—	—
Packaging materials	Weight, kg	Weight - % (versus the product)	Post-consumer material, weight - %
Carton	0,10	4,17 %	100 %
Wooden pallet	0,08	3,47 %	—
PS	0,04	1,82 %	—
Paper	0,01	0,46 %	10 %
PVC	0,01	0,42 %	—
TOTAL	0,25		

The product does not include in its life cycle any dangerous substances included in the “Very High Impact Candidate List for Authorization (SVHC)” in a percentage greater than 0.1% of the weight of the product.

## Environmental information

**These results are valid for the declared unit of 1 m (one lineal meter) of technical lineal modular luminaire system FIL, utilizing as reference the average for the entire family as representative as the variation between the different models is +/- 10 %.**

Estimated impact results are only relative statements that do not indicate impact category endpoints, exceeding threshold values, safety margins, or risks.

## Results per declared unit

Indicator	Unit	Tot.A1-A3	A4	A5	B1	B2	B3	B4	B5	B6	B7	C1	C2	C3	C4	D
GWP - total	kg CO <sub>2</sub> eq.	2,83E+01	1,64E+00	4,74E-02	0	0	0	0	0	7,11E+01	0	3,57E-02	1,17E-01	2,05E-01	1,24E-03	-1,25E+00
GWP - fossil	kg CO <sub>2</sub> eq.	2,81E+01	1,64E+00	4,25E-02	0	0	0	0	0	7,06E+01	0	3,55E-02	1,17E-01	2,05E-01	1,24E-03	-1,22E+00
GWP - biogenic	kg CO <sub>2</sub> eq.	9,80E-02	4,01E-04	4,73E-03	0	0	0	0	0	1,66E-01	0	8,34E-05	5,14E-05	1,40E-04	7,23E-07	-6,33E-03
GWP - luluc	kg CO <sub>2</sub> eq.	1,02E-01	3,67E-04	1,50E-04	0	0	0	0	0	2,92E-01	0	1,47E-04	6,61E-05	3,21E-05	3,45E-07	-2,65E-02
ODP	kg CFC 11 eq.	1,72E-06	3,67E-07	4,94E-09	0	0	0	0	0	7,00E-06	0	3,52E-09	2,34E-08	5,05E-09	5,10E-10	-1,45E-07
AP	mol H <sup>+</sup> eq.	1,93E-01	6,94E-03	2,83E-04	0	0	0	0	0	4,49E-01	0	2,26E-04	3,59E-04	2,61E-04	1,17E-05	-8,01E-03
EP - freshwater	kg PO <sub>4</sub> <sup>3-</sup> eq.	7,57E-02	1,10E-03	8,26E-05	0	0	0	0	0	1,27E-01	0	6,39E-05	7,42E-05	7,88E-05	1,94E-06	-2,63E-03
EP - freshwater	kg P eq	2,04E-02	7,59E-05	1,71E-05	0	0	0	0	0	3,25E-02	0	1,64E-05	1,33E-05	1,05E-05	1,27E-07	-6,94E-04
EP - marine	kg N eq.	3,18E-02	2,19E-03	5,95E-05	0	0	0	0	0	7,29E-02	0	3,67E-05	6,64E-05	9,72E-05	4,06E-06	-1,11E-03
EP - terrestrial	mol N eq.	3,23E-01	2,40E-02	6,22E-04	0	0	0	0	0	7,41E-01	0	3,72E-04	7,21E-04	9,82E-04	4,45E-05	-1,04E-02
POCP	kg NMVOC eq.	8,85E-02	6,70E-03	2,17E-04	0	0	0	0	0	2,02E-01	0	1,02E-04	2,69E-04	2,64E-04	1,29E-05	-3,79E-03
ADP - minerals & metals*	kg Sb eq.	6,65E-04	2,75E-05	3,68E-07	0	0	0	0	0	1,68E-04	0	8,43E-08	5,46E-06	3,66E-07	1,13E-08	-9,09E-06
ADP - fossil*	MJ	3,11E+02	2,33E+01	5,15E-01	0	0	0	0	0	8,33E+02	0	4,19E-01	1,64E+00	4,09E-01	3,42E-02	-1,29E+01
WDP	m <sup>3</sup>	8,64E+00	4,04E-02	1,34E-02	0	0	0	0	0	2,48E+01	0	1,24E-02	6,75E-03	7,40E-02	1,55E-03	-9,40E-02

**Acronyms** GWP-fossil = Global Warming Potential fossil fuels; GWP-biogenic = Global Warming Potential biogenic; GWP-luluc = Global Warming Potential land use and land use change; ODP = Depletion potential of the stratospheric ozone layer; AP = Acidification potential, Accumulated Exceedance; EP-freshwater = Eutrophication potential, fraction of nutrients reaching freshwater end compartment; EP-marine = Eutrophication potential, fraction of nutrients reaching marine end compartment; EP-terrestrial = Eutrophication potential, Accumulated Exceedance; POCP = Formation potential of tropospheric ozone; ADP-minerals&metals = Abiotic depletion potential for non-fossil resources; ADP-fossil = Abiotic depletion for fossil resources potential; WDP = Water (user) deprivation potential, deprivation-weighted water consumption.

\* Disclaimer: The results of this environmental impact indicator shall be used with care as the uncertainties of these results are high or as there is limited experience with the indicator.

## Potential environmental impact: additional mandatory indicators

### Results per declared unit

Indicator	Unit	Tot.A1-A3	A4	A5	B1	B2	B3	B4	B5	B6	B7	C1	C2	C3	C4	D
GWP - GHG*	kg CO <sub>2</sub> eq.	2,75E+01	1,63E+00	4,57E-02	0	0	0	0	0	6,98E+01	0	3,51E-02	1,15E-01	2,05E-01	1,21E-03	-1,20E+00

\* The indicator includes all greenhouse gases included in GWP-total but excludes biogenic carbon dioxide uptake and emissions and biogenic carbon stored in the product. This indicator is thus almost equal to the GWP indicator originally defined in EN 15804:2012+A1:2013.

# Use of resources

## Results per declared unit

Indicator	Unit	Tot.A1-A3	A4	A5	B1	B2	B3	B4	B5	B6	B7	C1	C2	C3	C4	D
PERE	MJ	5,77E+01	2,25E-01	1,08E-01	0	0	0	0	0	2,12E+02	0	1,07E-01	2,64E-02	2,86E-02	2,80E-04	-7,22E+00
PERM	MJ	0	0	0	0	0	0	0	0	0	0	0	0	0	0	0
PERT	MJ	5,77E+01	2,25E-01	1,08E-01	0	0	0	0	0	2,12E+02	0	1,07E-01	2,64E-02	2,86E-02	2,80E-04	-7,22E+00
PENRE	MJ	4,00E+02	2,51E+01	8,07E-01	0	0	0	0	0	1,40E+03	0	7,02E-01	1,77E+00	4,78E-01	3,67E-02	-1,93E+01
PENRM	MJ	0	0	0	0	0	0	0	0	0	0	0	0	0	0	0
PENRT	MJ	4,00E+02	2,51E+01	1,08E-01	0	0	0	0	0	1,40E+03	0	7,02E-01	1,77E+00	4,78E-01	3,67E-02	-1,93E+01
SM	kg	0	0	0	0	0	0	0	0	0	0	0	0	0	0	0
RSF	MJ	0	0	0	0	0	0	0	0	0	0	0	0	0	0	0
NRSF	MJ	0	0	0	0	0	0	0	0	0	0	0	0	0	0	0
FW	m <sup>3</sup>	9,67E+00	4,53E-02	1,50E-02	0	0	0	0	0	2,48E+01	0	1,24E-02	6,75E-03	7,40E-02	1,55E-03	-9,40E-02

Acronyms  
 PERE = Use of renewable primary energy excluding renewable primary energy resources used as raw materials; PERM = Use of renewable primary energy resources used as raw materials; PERT = Total use of renewable primary energy resources; PENRE = Use of non-renewable primary energy excluding non-renewable primary energy resources used as raw materials; PENRM = Use of non-renewable primary energy resources used as raw materials; PENRT = Total use of non-renewable primary energy re-sources; SM = Use of secondary material; RSF = Use of renewable secondary fuels; NRSF = Use of non-renewable secondary fuels; FW = Use of net fresh water.



## Information on biogenic carbon content

### Results per declared unit

<b>BIOGENIC CARBON CONTENT</b>	<b>Unit</b>	<b>Quantity</b>
Biogenic carbon content in product	kg C	0
Biogenic carbon content in packaging	kg C	1,32E+01

Note: 1 kg biogenic carbon is equivalent to 44/12 kg CO<sub>2</sub>.

# Environmental impacts of 1 metre of Fil luminaire considering 5 years of use

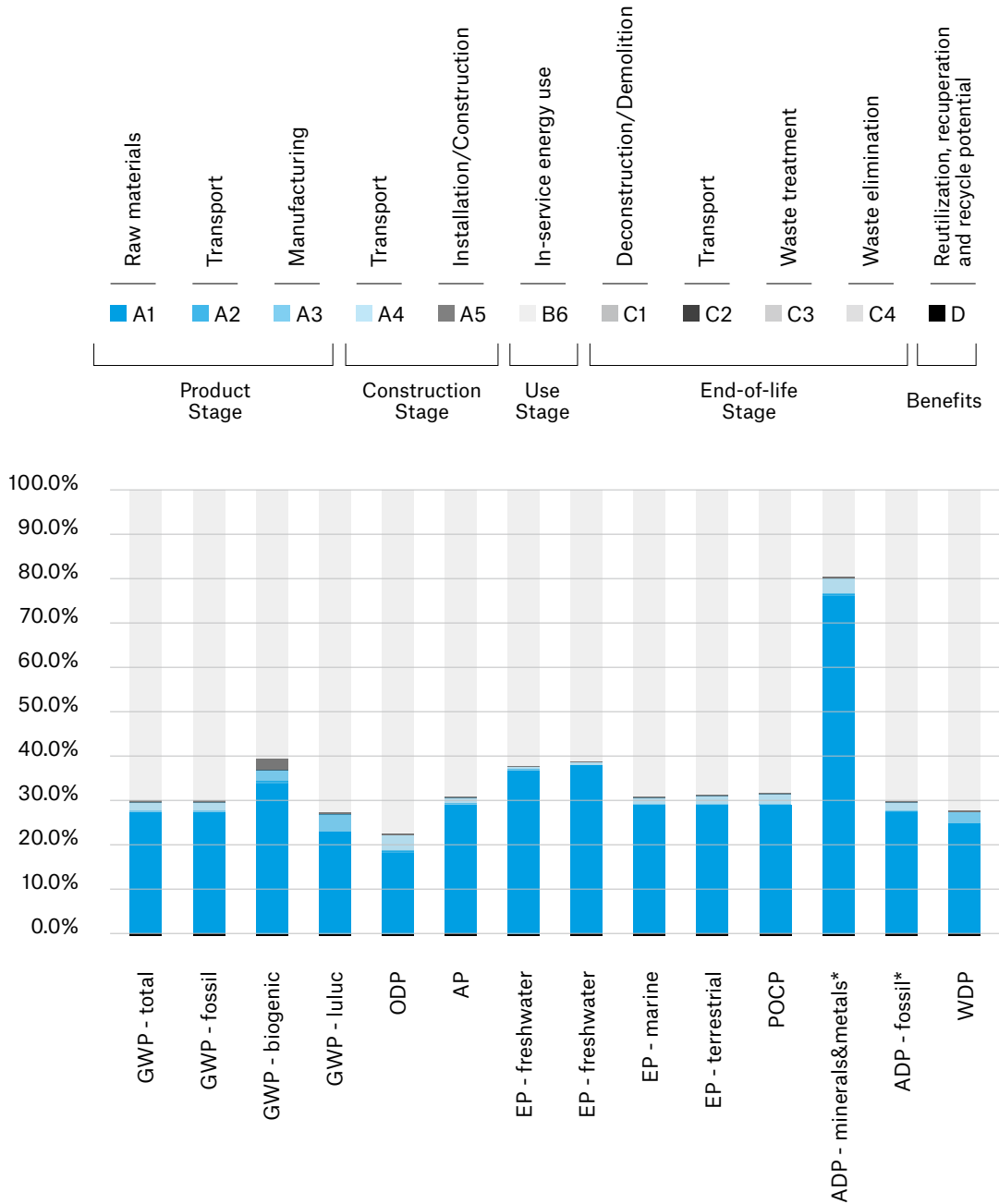

Acronyms

GWP-fossil = Global Warming Potential fossil fuels; GWP-biogenic = Global Warming Potential biogenic; GWP-luluc = Global Warming Potential land use and land use change; ODP = Depletion potential of the stratospheric ozone layer; AP = Acidification potential, Accumulated Exceedance; EP-freshwater = Eutrophication potential, fraction of nutrients reaching freshwater end compartment; EP-marine = Eutrophication potential, fraction of nutrients reaching marine end compartment; EP-terrestrial = Eutrophication potential, Accumulated Exceedance; POCP = Formation potential of tropospheric ozone; ADP-minerals&metals = Abiotic depletion potential for non-fossil resources; ADP-fossil = Abiotic depletion for fossil resources potential; WDP = Water (user) deprivation potential, deprivation-weighted water consumption

\* The results of this environmental impact indicator shall be used with care as the uncertainties of these results are high or as there is limited experience with the indicator.

Unit	Indicator	A1-A3	A4	A5	B1	B2	B3	B4	B5	B6	B7	C1	C2	C3	C4	D
kg CO <sub>2</sub> eq.	GWP – Fossil	2,81E+01	1,64E+00	4,25E-02	0	0	0	0	0	7,06E+01	0	3,55E-02	1,17E-01	2,05E-01	1,24E-03	-1,22E+00
kg CO <sub>2</sub> eq.	GWP – Biogenic	9,80E-02	4,01E-04	4,73E-03	0	0	0	0	0	1,66E-01	0	8,34E-05	5,14E-05	1,40E-04	7,23E-07	-6,33E-03
kg CO <sub>2</sub> eq.	GWP – Land Use	1,02E-01	3,67E-04	1,50E-04	0	0	0	0	0	2,92E-01	0	1,47E-04	6,61E-05	3,21E-05	3,45E-07	-2,65E-02
kg CO <sub>2</sub> eq.	GWP – Total	2,83E+01	1,64E+00	4,74E-02	0	0	0	0	0	7,11E+01	0	3,57E-02	1,17E-01	2,05E-01	1,24E-03	-1,25E+00

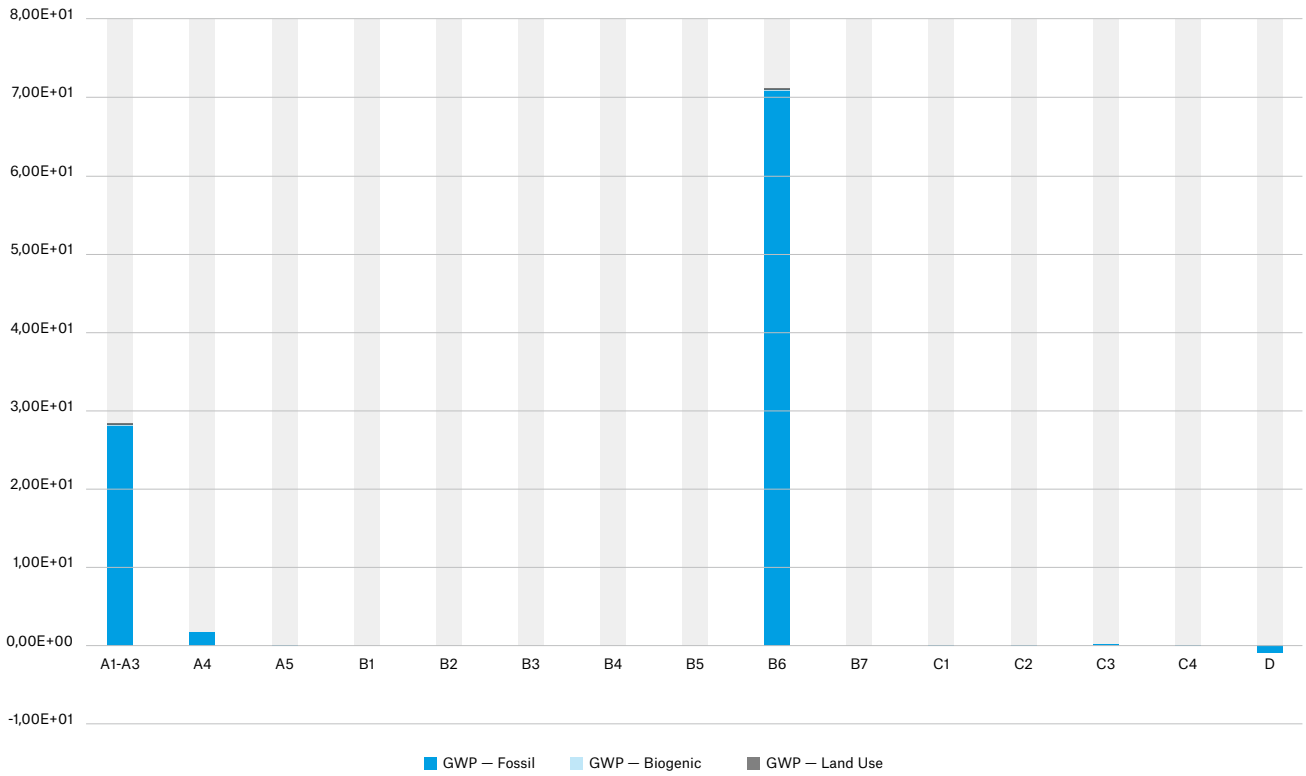



Impact category	A1	A2	A3	A4	A5	B6	C1	C2	C3	C4	D	Total
Climate change	7,63E-01	2,82E-03	5,35E-03	7,44E-02	2,26E-03	1,95E+00	9,80E-04	2,60E-03	5,92E-03	1,73E-05	-3,54E-02	<b>2,81E+00</b>
Ozone depletion	1,68E-03	2,98E-05	3,74E-05	7,79E-04	4,57E-06	6,19E-03	3,11E-06	2,62E-05	5,95E-06	1,62E-07	-1,56E-04	<b>8,75E-03</b>
Acidification	2,14E-01	6,12E-04	1,75E-03	1,41E-02	3,09E-04	4,96E-01	2,50E-04	2,24E-04	3,05E-04	7,63E-06	-9,49E-03	<b>7,28E-01</b>
Eutrophication	0,00E+00	0,00E+00	0,00E+00	0,00E+00	0,00E+00	0,00E+00	0,00E+00	0,00E+00	0,00E+00	0,00E+00	0,00E+00	<b>0,00E+00</b>
Eutrophication, freshwater	4,54E-02	9,73E-07	2,21E-04	2,36E-05	3,35E-05	6,16E-02	3,10E-05	3,97E-06	1,72E-05	4,11E-08	-1,22E-03	<b>1,07E-01</b>
Eutrophication, marine	4,31E-02	1,79E-04	6,73E-04	6,69E-03	8,42E-05	9,82E-02	4,94E-05	4,82E-05	1,47E-04	4,50E-06	-1,45E-03	<b>1,49E-01</b>
Eutrophication, terrestrial	6,40E-02	2,77E-04	7,76E-04	1,02E-02	1,29E-04	1,51E-01	7,61E-05	7,57E-05	2,21E-04	6,85E-06	-2,22E-03	<b>2,27E-01</b>
Photochemical ozone formation	1,00E-01	4,35E-04	1,42E-03	1,49E-02	2,58E-04	2,35E-01	1,18E-04	1,47E-04	3,31E-04	1,07E-05	-4,61E-03	<b>3,53E-01</b>
Resource use, minerals and metals	1,36E+00	5,17E-06	9,13E-05	1,46E-04	1,74E-06	2,92E-03	1,47E-06	9,70E-06	2,57E-05	3,80E-08	-3,47E-03	<b>1,36E+00</b>
Resource use, fossils	5,02E-01	1,94E-03	8,44E-03	5,12E-02	1,02E-03	1,83E+00	9,22E-04	1,78E-03	5,95E-04	1,13E-05	-2,57E-02	<b>2,40E+00</b>
Water use	6,52E-02	-1,90E-06	5,15E-03	2,71E-05	9,63E-05	1,92E-01	9,64E-05	4,01E-06	6,06E-04	2,65E-08	-8,58E-04	<b>2,63E-01</b>
Human toxicity, non-cancer	6,86E-02	6,06E-05	1,80E-04	2,49E-03	1,67E-04	3,98E-02	2,00E-05	5,17E-05	2,85E-04	5,33E-07	-4,40E-03	<b>1,12E-01</b>
Human toxicity, cancer	4,22E-02	1,05E-05	3,04E-04	2,03E-04	4,27E-04	1,59E-02	7,99E-06	8,53E-06	3,35E-05	6,91E-08	-8,48E-03	<b>5,91E-02</b>
Ecotoxicity, freshwater	3,55E-01	2,63E-04	1,60E-03	6,23E-03	2,16E-04	2,89E-01	1,45E-04	2,65E-04	1,67E-03	2,02E-06	-1,00E-02	<b>6,55E-01</b>
Land use	5,73E-03	3,94E-07	1,74E-03	1,01E-05	6,02E-06	1,11E-02	5,57E-06	7,05E-07	4,43E-06	1,05E-06	-3,59E-05	<b>1,86E-02</b>
Particulate matter	2,33E-01	8,41E-04	2,70E-03	7,74E-03	3,57E-04	2,29E-01	1,15E-04	6,71E-04	6,75E-04	2,76E-05	-1,48E-02	<b>4,75E-01</b>
Ionising radiation	1,91E-02	7,84E-05	2,02E-04	2,07E-03	7,41E-05	1,40E-01	7,02E-05	7,08E-05	2,33E-05	4,42E-07	-1,58E-03	<b>1,61E-01</b>
<b>Total</b>	<b>3,88E+00</b>	<b>7,56E-03</b>	<b>3,06E-02</b>	<b>1,91E-01</b>	<b>5,44E-03</b>	<b>5,75E+00</b>	<b>2,89E-03</b>	<b>5,99E-03</b>	<b>1,09E-02</b>	<b>9,02E-05</b>	<b>-1,24E-01</b>	<b>9,88E+00</b>

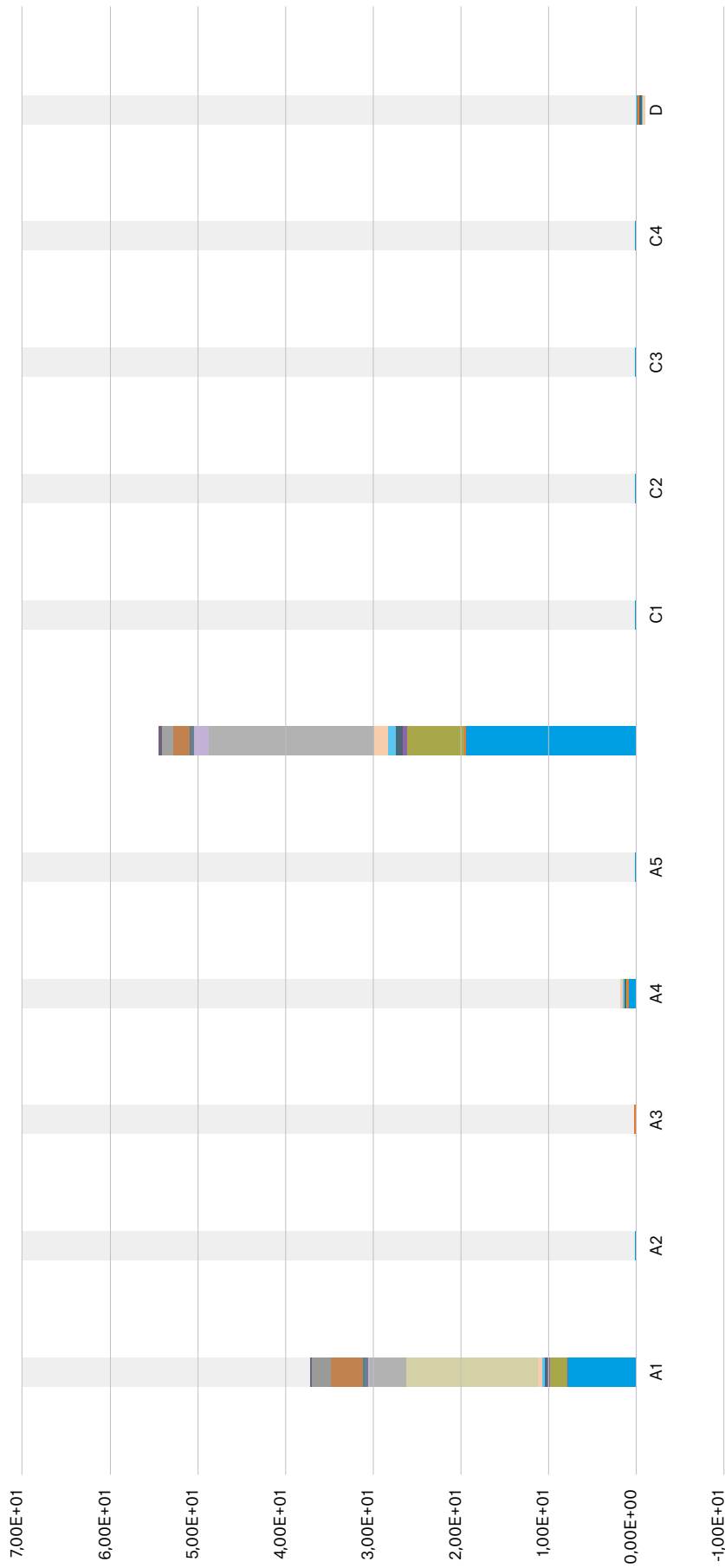

## Information related to Sector EPD

The present EPD® is individual.

Change of format.

Addition of new photos and diagrams.

## References

- General Programme Instructions of the International EPD® System. Version 4.
- ISO 14020: 2000 Etiquetas y declaraciones medioambientales: principios generales.
- ISO 14025: 2010 Etiquetas y declaraciones ambientales - Declaraciones ambientales tipo III -Principios y procedimientos.
- ISO 14040: 2006 Gestión ambiental - Evaluación del ciclo de vida - Principios y marco.
- ISO 14044: 2006 Gestión ambiental - Evaluación del ciclo de vida - Requisitos y directrices.
- PCR 2019:14 Construction products (EN 15804: A2) version 1.11.
- UNE-EN 15804:2012+A2:2019 Sostenibilidad de las obras de construcción - Declaraciones de productos ambientales - Reglas básicas para la categoría de productos de construcción.
- Marcel Gómez Consultoría Ambiental (2022). Memoria del Análisis del Ciclo de Vida FIL. Barcelona

**LAMP**  
Worktitude for light